

Cal. PC21J

ϕ 18.50 mm

H 3.15 mm

Item	Version No.
Specification	Version 3
Appearance	Version 2
Casing	Version 2
Hand Fitting	Version 2
Hand Setting Stem	Version 1
Dial - 1	Version 1
Casing Ring	Version 1
Assembly Plan	Version 2
Hands	Version 1



MOVEMENT SPECIFICATIONS

CAL.PC21J 6 3/4 X 8 Ligne Quartz Movement Three Hands

1. MOVEMENT DIMENSIONS

- Outside diameter ϕ 18.20mm (12H~6H) x 14.11mm (3H~9H), ϕ 18.50mm
- Casing diameter ϕ 17.80mm (12H~6H) , ϕ 18.10mm
- Total height 3.15 mm (including the battery)

2. TIME STANDARD

- Type of quartz oscillator Tuning fork
- Frequency of quartz oscillator 32,768 H Z
- Accuracy Monthly rate: Less than 20 seconds per month at normal temperature range
- Regulation device Nil
- Regulation hands unbalance
 - Second : Less than 0.07 μ N·m (7mg·mm)
 - Minute : Less than 0.30 μ N·m (30mg·mm)
 - Hour : Less than 0.30 μ N·m (30mg·mm)

3. BATTERY

- Type Silver oxide battery
- Size ϕ 6.8 x t 2.6 (mm)
- Battery life Approx. 3 years
- Recommended battery SR626SW (SEIZAIKEN)

4. STEPPING MOTOR

- Type Two pole stepping motor
- Step 180° every second

5. JEWEL

0 jewel

6. ANTIMAGNETISM

(direct current magnetic field)

\geq 1600 A / m

7. SHOCK RESISTANCE

On equal level with general quartz movement

8. OPERATING TEMPERATURE RANGE

From - 5 °C to + 50 °C

9. SETTING MECHANISM

- Crown at normal position Free
- Crown pulled out to 1st click Time setting, second setting and reset switch

10. TEST OF ACCURACY

- Equipment to be used SEIKO Quartz Tester QT - 99
Greiner Quartz Timer - C
Witschi Q-Tester 4000
- Duration of measurement 10 seconds
- Microphone to be used Electromagnetic detection type (DM-1)

11. ATTACHED PARTS

Parts Name	Parts Code
Silver oxide battery	3016 - 18G0
Hand setting stem	0354 - 1220

*** All specifications are subject to change without notice.**

SII Products

Version: 3

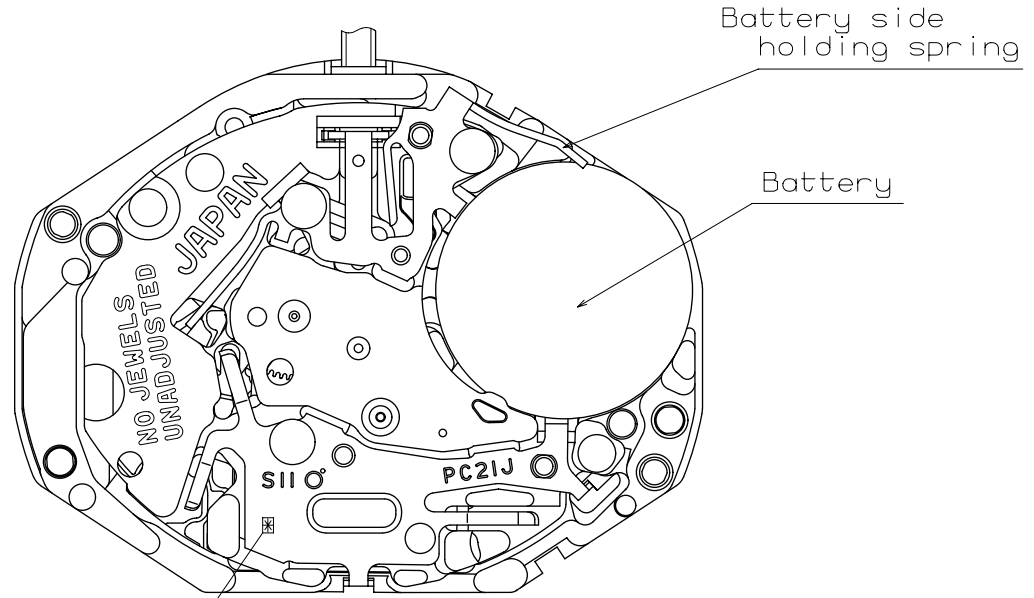

	*
TYPE M	NO MARK

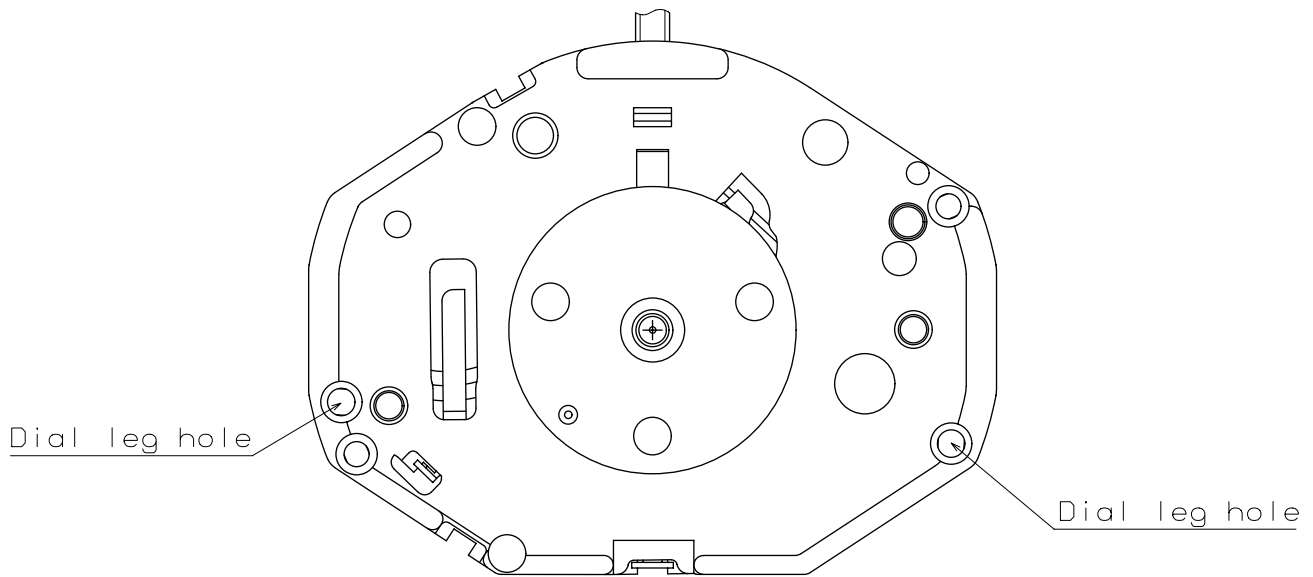

Scale : 5/1
Unit : 1=1/100mm

Version:2

Casing

Cal. PC21J

Battery Side Holding Spring Type

* pull out stroke:56

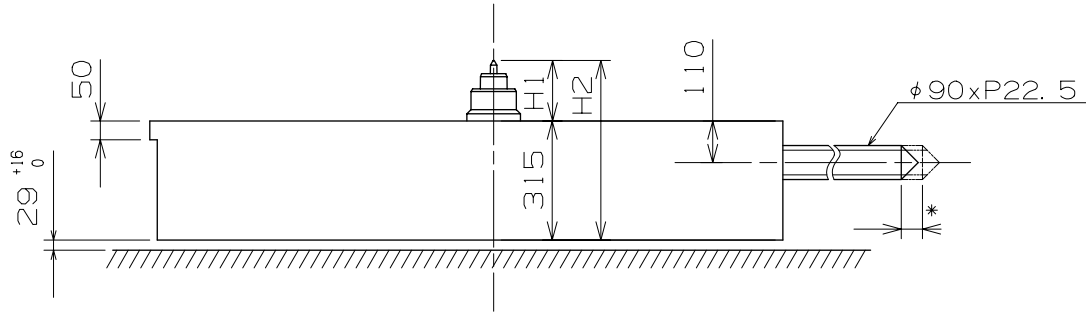

Center Post		TYPE M
Maximum height from main plate surface	H1	160
Total height incl. movement	H2	475

Hand Setting Stem	TYPE A	TYPE B
L1	2012	2472

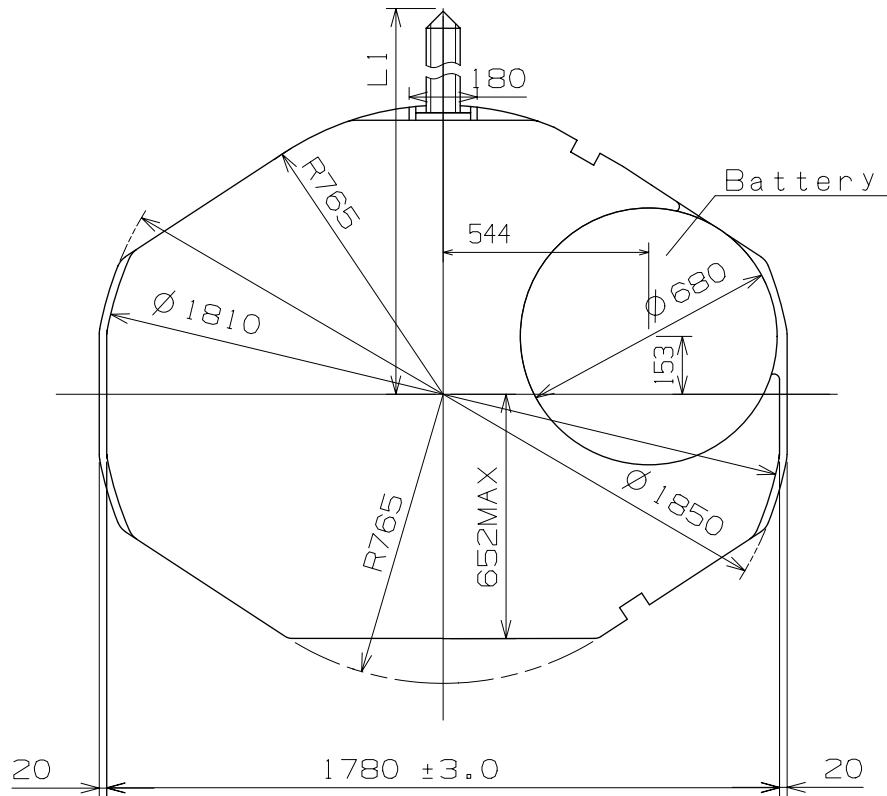

Scale : 5/1
Unit : 1=1/100mm

Version:2

Casing

Cal. PC21J

Battery Side Holding Spring Type

* pull out stroke:56

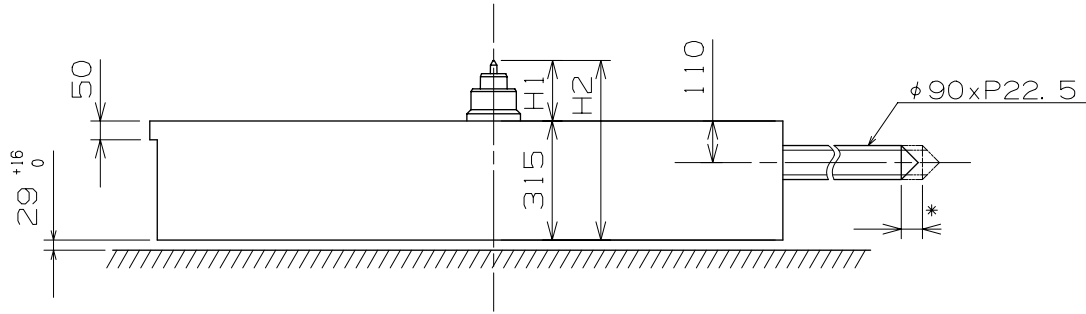

Center post 中心柱位		TYPE M 一般針高
Maximum height from main plate surface. 與機芯平面之最大高度	H1	160
Total height incl. movement. 機芯總高度	H2	475

Hand Setting Stem	TYPE A	TYPE B
L1	2012	2472

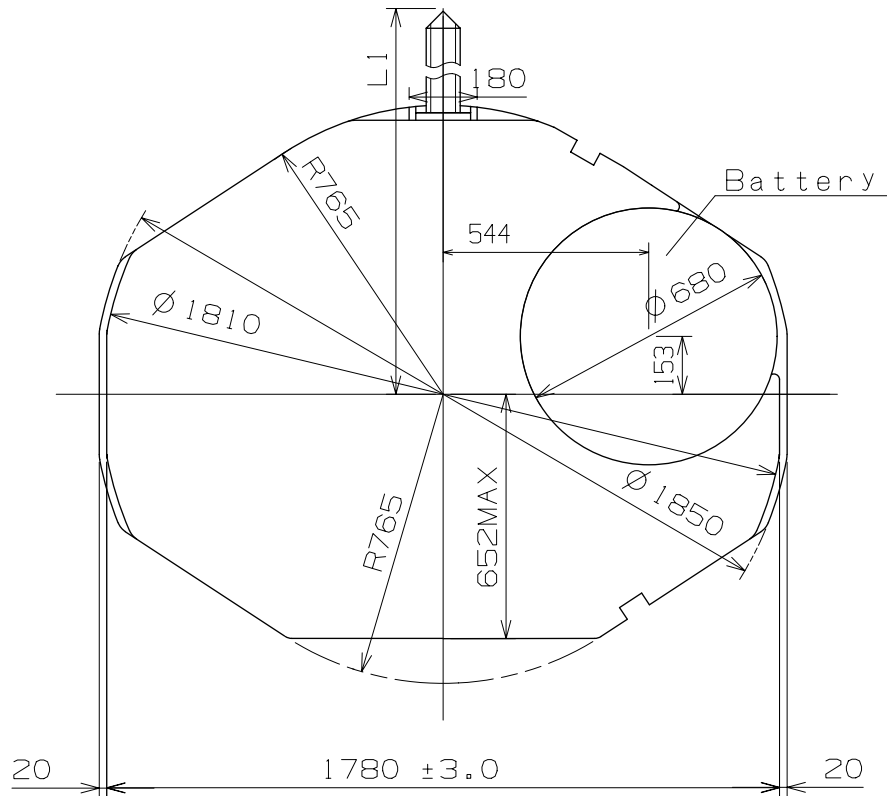

Scale : 5/1
Unit : 1=1/100mm

Version:2

Hand Fitting

Cal. PC21J

Hour hand unbalance $\leq 0.3 \mu\text{N}\cdot\text{m}$ (30mg·mm)
 Minute hand unbalance $\leq 0.3 \mu\text{N}\cdot\text{m}$ (30mg·mm)
 Second hand unbalance $\leq 0.07 \mu\text{N}\cdot\text{m}$ (7mg·mm)

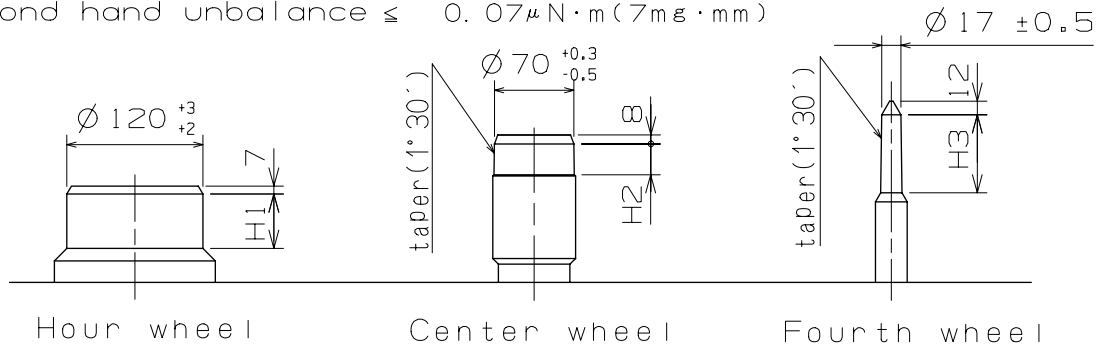

	Part. No.			Dimension		
	Hour wheel	Center wheel	Fourth wheel	H1	H2	H3
TYPE M	0271 3940	0221 0240	0241 2070	48	27	69

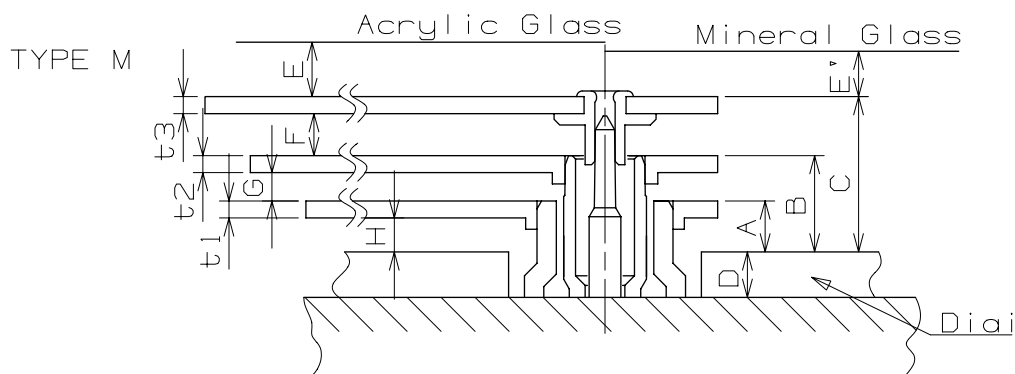

	A	B	C	D	E	E'	F	G	H	t1	t2	t3
TYPE M	45	85	137	40	*	*	37	25	30	15	15	15

*	J		
	Max	800	800~850
E'	Min 40	Min 45	Min 65
E	Min 48	Min 53	Min 73

Scale : 15/1
 Unit : 1=1/100mm

Version:2

Hand Fitting

Cal. PC21J

Hour hand unbalance $\leq 0.3 \mu\text{N}\cdot\text{m}$ (30mg·mm)
 Minute hand unbalance $\leq 0.3 \mu\text{N}\cdot\text{m}$ (30mg·mm)
 Second hand unbalance $\leq 0.07 \mu\text{N}\cdot\text{m}$ (7mg·mm)

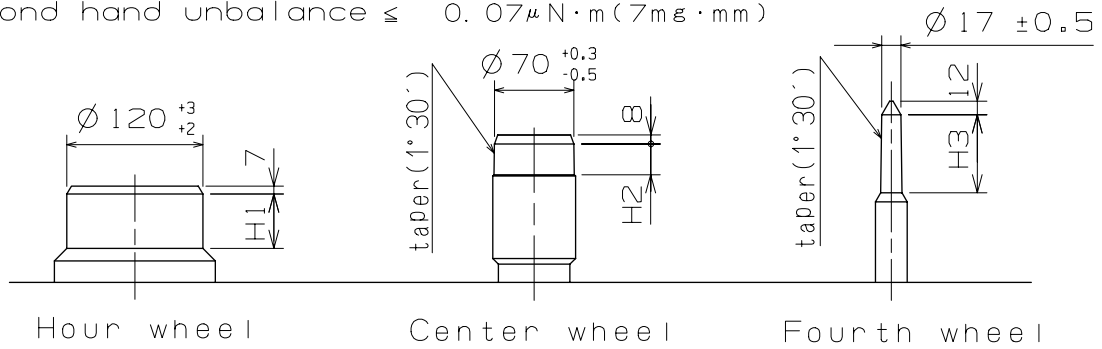

	Part. No.			Dimension		
	Hour wheel 時針輪	Center wheel 分針輪	Fourth wheel 秒針輪	H1	H2	H3
TYPE M 一般針高	0271 3940	0221 0240	0241 2070	48	27	69

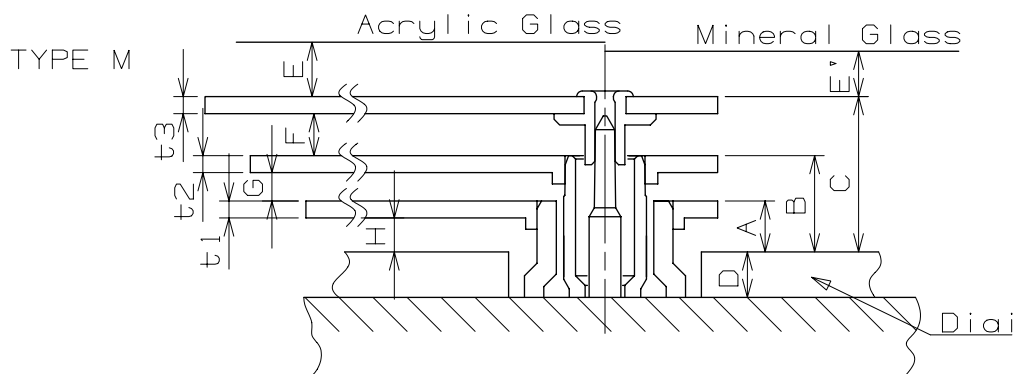

	A	B	C	D	E	E'	F	G	H	t1	t2	t3
TYPE M 一般針高	45	85	137	40	*	*	37	25	30	15	15	15

*	J		
	Max	800	800~850
E'	Min 40	Min 45	Min 65
E	Min 48	Min 53	Min 73

Scale : 15/1
 Unit : 1=1/100mm

Version:2

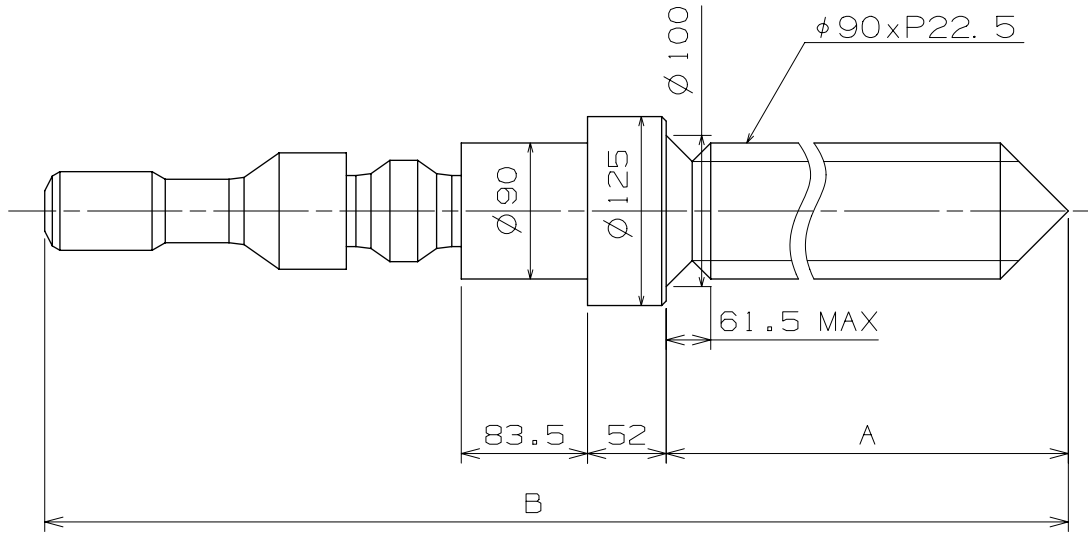

	Part. No.	A	B
TYPE A	0354 1220	1303	1714
TYPE B	0354 1270	1763	2174

Do not lubricate the hand setting stem.

Scale : 20/1
Unit : 1=1/100mm

Version:1

Dial - 1

Cal. PC21J

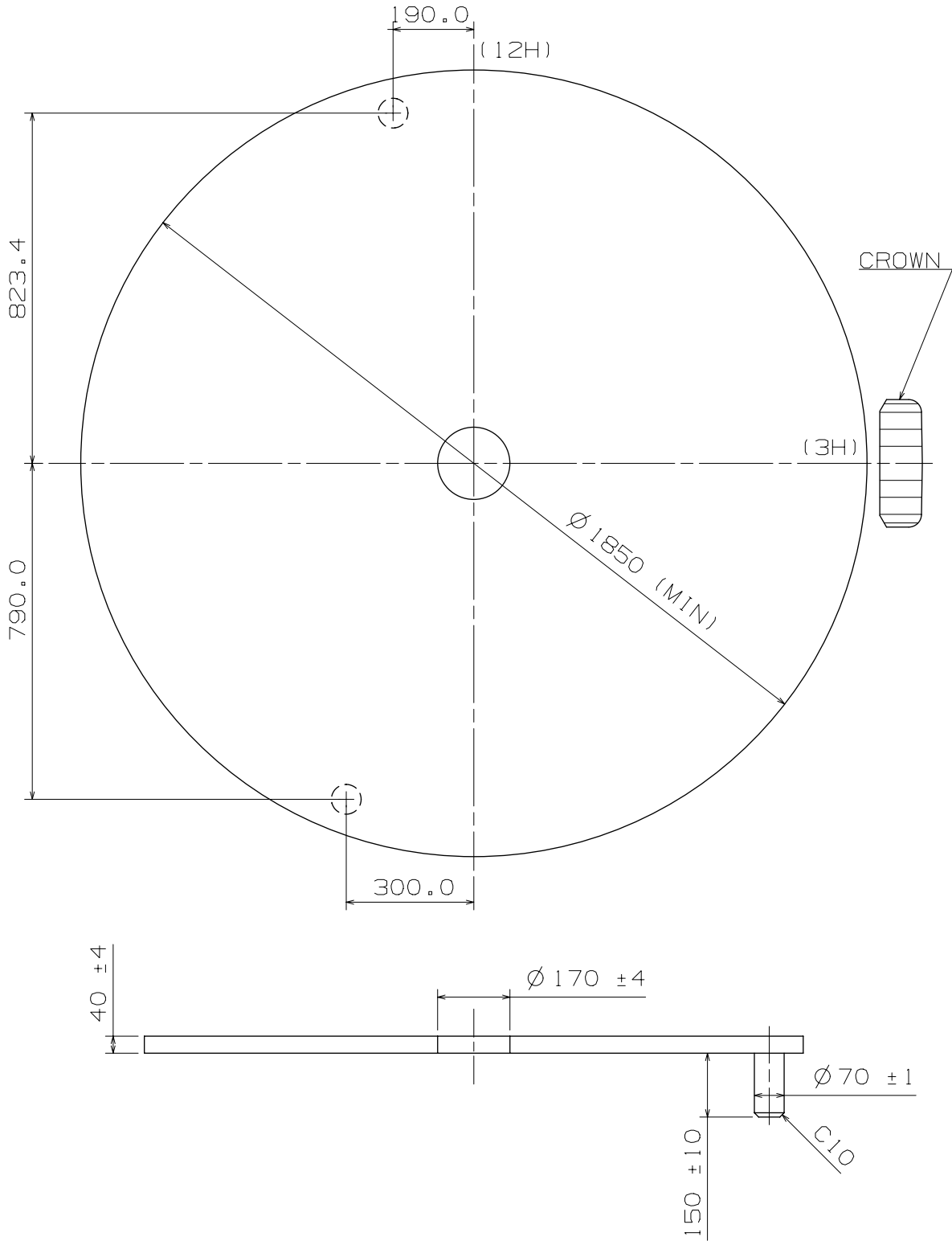

Scale : 7/1

Unit : 1=1/100

Version:1

Casing Ring

Cal. PC21J

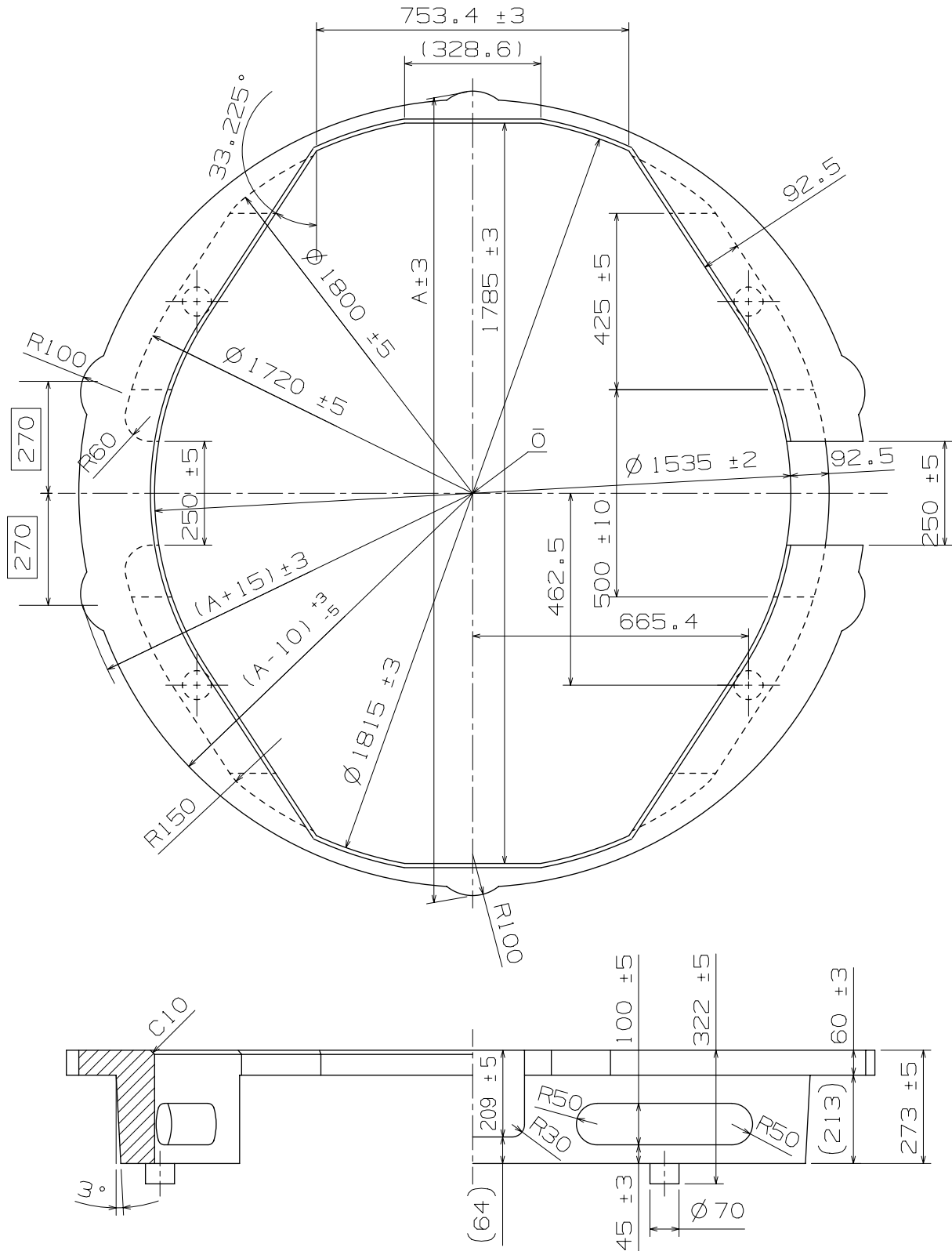

Scale : 7/1
Unit : 1=1/100

Version:1

Assembly Plan

Cal. PC21J

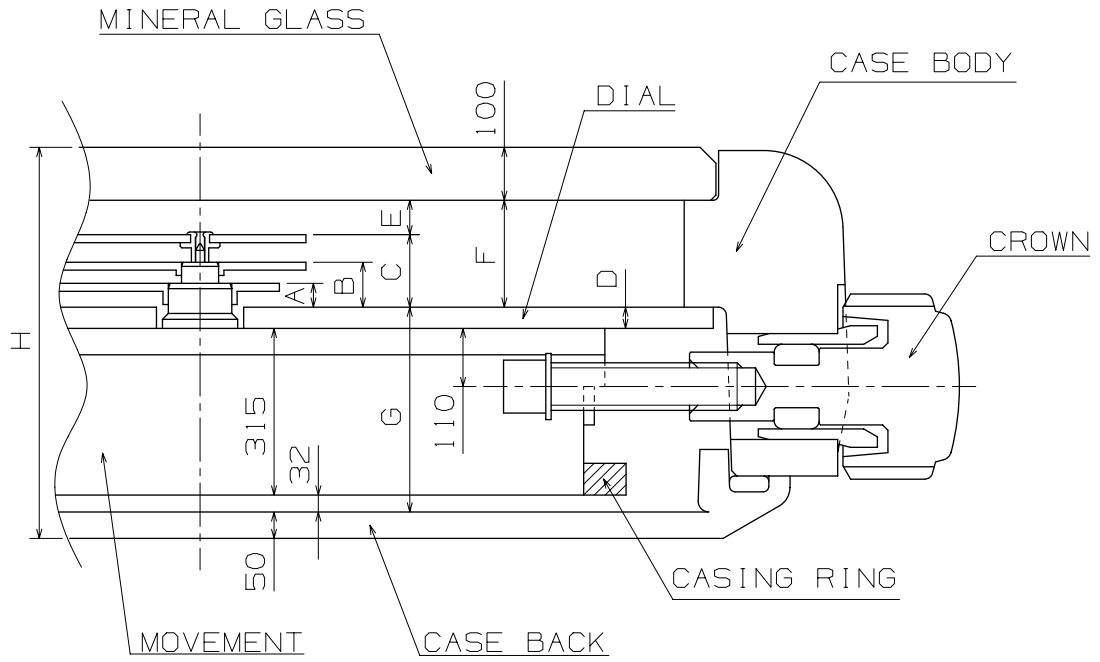

	A	B	C	D	E	F	G	H
TYPE M	45	85	137	40	65	202	387	739

Scale : \neq

Unit : 1=1/100

Version:2

SECOND

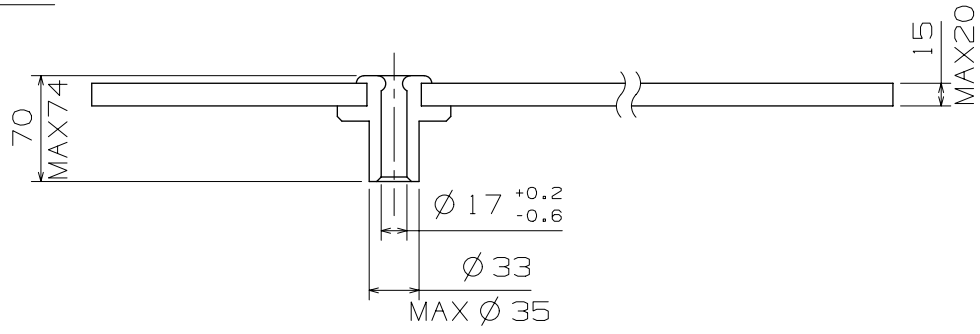

MINUTE

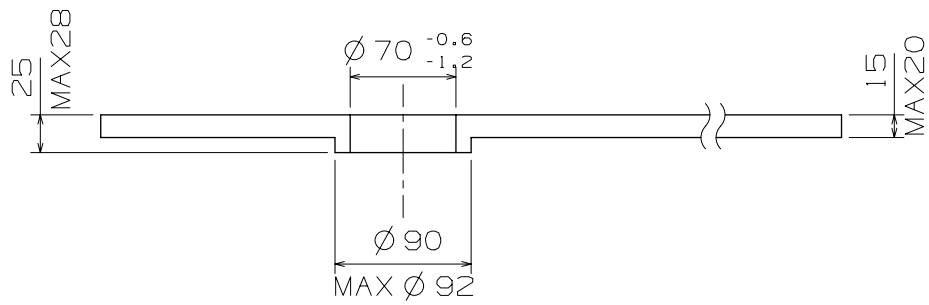

HOUR

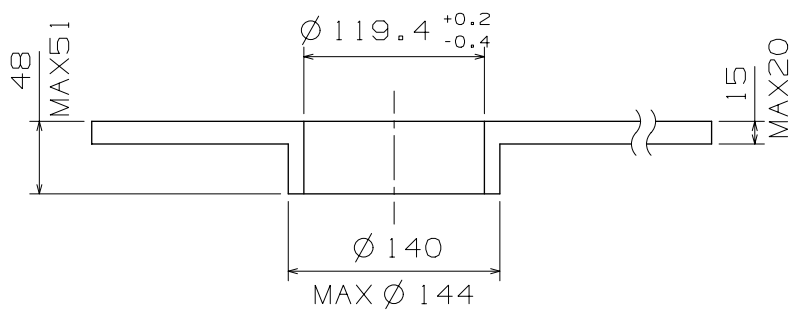

Scale : 20/1

Unit : 1=1/100

Version: 1

OPERATION MANUAL

2 Hands / 3 Hands

TIME SETTING

[2 Hands]

- 1) Pull out the crown.
- 2) Turn the crown to set hour and minute hands.
- 3) Push the crown back in to normal position.

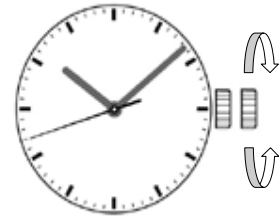





[3 Hands]

- 1) Pull out the crown when the second hand is at the 12 o'clock position
- 2) Turn the crown to set hour and minute hands.
- 3) Push the crown back in to normal position in accordance with the time signal.

PC Standard Series (2 Hands/3 Hands) - Calibre List





Date : 20.10.2016

Reference	PC10A1	PC11A1	PC21S2M	PC21S7M
Product Line	PC Standard Series	PC Standard Series	PC Standard Series	PC Standard Series
Function	2 Hands	3 Hands	3 Hands	3 Hands
Appearance				
Size	5 1/2"	5 1/2"	6 3/4" X 8"	6 3/4" X 8"
*Category	A	A	A	B
Spec Sheet Dial Drawing No.	PC10 Dial - 1	PC11 Dial - 1	PC21S Dial - 1	PC21S Dial - 1
Postion	Stem	3H	3H	3H
Hands Fitting Type	Hands : TYPE M	Hands : TYPE M	Hands : TYPE M	Hands : TYPE M
Stem Type	Standard	Standard	Standard	Long
Remarks				

*Category A : Ordinary Production (Stock Item) ; Category B : Order Based Production

PC Standard Series (2 Hands/3 Hands) - Calibre List

Date : 20.10.2016

Reference	PC21J2	PC21J7	PC21AE2	PC21AE3
Product Line	PC Standard Series	PC Standard Series	PC Standard Series	PC Standard Series
Function	3 Hands	3 Hands	3 Hands	3 Hands
Appearance				
Size	6 3/4" X 8"	6 3/4" X 8"	6 3/4" X 8"	6 3/4" X 8"
*Category	A	B	B	B
Spec Sheet Dial Drawing No.	PC21J Dial - 1	PC21J Dial - 1	PC21AE Dial - 1	PC21AE Dial - 1
Postion	Stem	3H	3H	3H
Hands Fitting Type	Hands : TYPE M	Hands : TYPE M	Hands : TYPE L	Hands : TYPE L
Stem Type	Standard	Long	Standard	Long
Remarks				

*Category A : Ordinary Production (Stock Item) ; Category B : Order Based Production

PC Standard Series (2 Hands/3 Hands) - Calibre List

Date : 20.10.2016

Reference	PC21AF2			
Product Line	PC Standard Series			
Function	3 Hands			
Appearance				
Size	6 3/4" X 8"			
*Category	B			
Spec Sheet Dial Drawing No.	PC21AF Dial - 1			
Postion	Stem	3H		
Hands Fitting Type	Hands : TYPE LL			
Stem Type	Long			
Remarks				

*Category A : Ordinary Production (Stock Item) ; Category B : Order Based Production